

SPECIFICATION SHEET

PRODUCT FAMILY: **SINKS** FINISH: **STAINLESS STEEL** SERIES: **ARIANE** MODEL: **ARX 160**

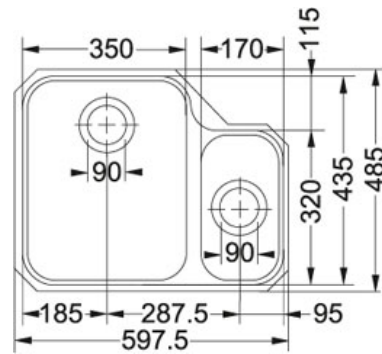

Product Information

Article Number	122.0154.935
Price	£ 390.24
Cabinet Size	600 mm
Bowl Size	350 mm x 435 mm x 195 mm
Small Bowl Size	170 mm x 320 mm x 150 mm
Cut-Out Template	Yes
Download Cut-Out Template	Click here
Position of small bowl	Right hand side
Surface Finish	X BRUSHED/SATIN
Opposite Configuration	122.0154.926

Accessories



112.0006.086



112.0006.088



112.0006.090



112.0036.491



112.0038.361



112.0050.988



112.0066.307



112.0073.712

Suggested Products



112.0052.536



115.0049.980



115.0051.538



133.0026.896



134.0049.848