

SPECIFICATION SHEET

PRODUCT FAMILY: **SINKS** FINISH: **STAINLESS STEEL** SERIES: **KUBUS** MODEL: **KBX 160-34/16**

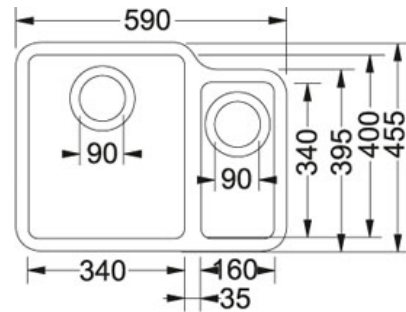

Product Information

Article Number	122.0033.137
Price	£ 432.84
Cabinet Size	600 mm
Bowl Size	340 mm x 400 mm x 175 mm
Small Bowl Size	160 mm x 340 mm x 150 mm
Cut-Out Template	Yes
Download Cut-Out Template	Click here
Position of small bowl	Right hand side
Surface Finish	X BRUSHED/SATIN
Opposite Configuration	122.0033.122

Accessories



112.0014.121



112.0014.122



112.0014.124



112.0050.988

Suggested Products



112.0052.536



115.0049.965



115.0049.966



115.0051.539



134.0049.848